



## FR NEOSTAR

Dry coolers

Notice technique d'installation

Installation instructions

Installationsnotiz

Manual tecnico de instalacion

Oryginalna instrukcja

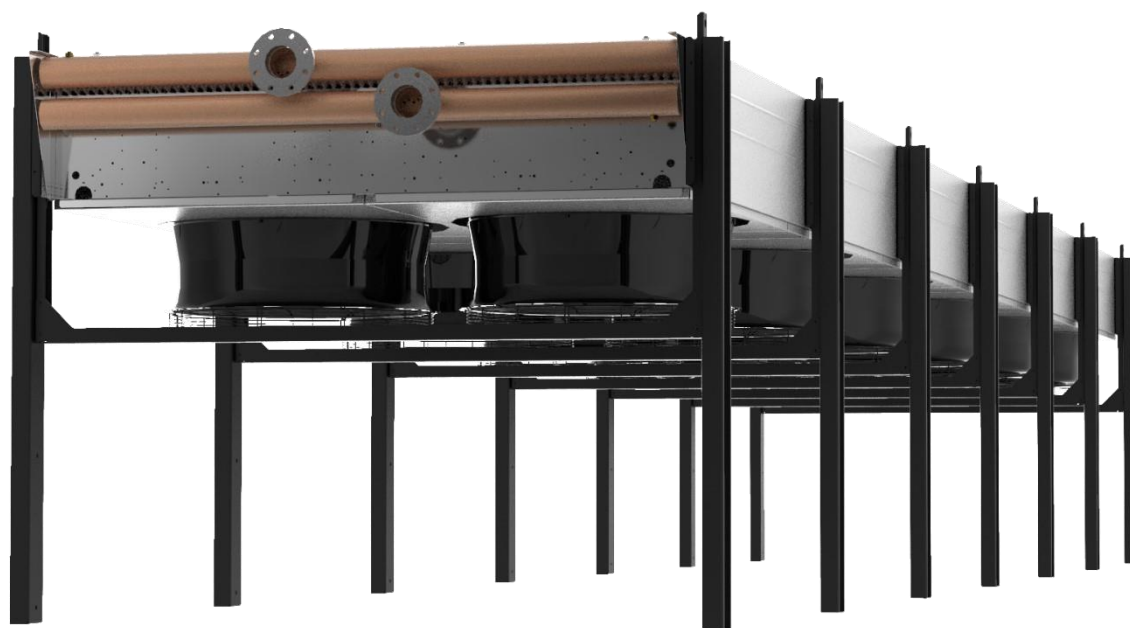

Cooling solutions, delivered with care.

[www.frigabohn.com](http://www.frigabohn.com)

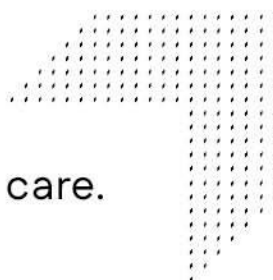

## UTILISATION

**FCR NEOSTAR** : Compacité et hautrendement.

**FIR NEOSTAR** : Faible perte de charge et fortepuissance.

Les aéroréfrigérantsFC/FI NEOSTARsontdestinés au conditionnementd'air, «free cooling»... et refroidissementde tous fluides compatibles avec le cuivre, dontla température maximale à l'entréene dépasse pas 100°C.

La température de l'air réchauffé ne doitpas dépasser les valeursmaximalesadmises par les ventilateurs. Voir§6.

Le point de congélation du fluidedoittoujours être inférieur d'aumoins5K à la température hivernaleminimaleambiante du lieu de l'installation.

Un aéroréfrigérant standard ne peutse vidanger totalement par simple ouverturedes orifices depurge.

L'installation et la maintenance doivent êtreréalisées par un professionnel.

## USE

**FCR NEOSTAR** : Compactness and

high efficiency. **FIR NEOSTAR** : Low pressure

drop and high capacity.

The FC/FI NEOSTAR dry coolers are designed to air conditioning, free cooling... and cooling all kinds of fluids compatible with copper, with a maximum inlet temperature of 100°C.

The temperature of air outlet should not exceed maximum temperature specifications for the fans.

See §6. The freezing point of the fluid must be at least 5K below the minimum winter ambient temperature of the site of installation.

A standard dry cooler cannot be fully drained simply by opening the drain

fitting orifices. The installation and maintenance must be done by a professional.

## ANWENDUNG

**FCR NEOSTAR** : Kompaktheit und hohe Effizienz.

**FIR NEOSTAR** : Geringer Druckverlust und sehr leistungsstarker.

Die Anwendungen der GlykolrückkühlerFC/FI NEOSTAR sind Klimanlagen, Free cooling... und Kühlung von allen kupferverträglichen Flüssigkeiten, deren maximale Eintrittstemperatur unter 100°C liegt.

Die Luftaustrittstemperatur darf die maximale zulässige Temperaturen der Ventilatoren nicht überschreiten.

Siehe §6. Der Gefrierpunkt des Mediums muss im Winter immer mindestens 5K unter der tiefsten Umgebungstemperatur am Installationsort liegen.

Der Standardglykolrückkühler kann durch einfaches Öffnen der Ablaufstutzen nicht vollständig geleert werden. Ein Fachmann muss die Installation und die Wartung durchführen.

## USAR

**FCR NEOSTAR** : Compacidad y alta eficiencia

**FIR NEOSTAR** : Baja pérdida de carga y fuerte potencia.

Los aerorrefrigerantesFC/FI NEOSTARson adaptados al acondicionamiento de aire, «free cooling»...y refrigeración de todos los fluidos compatibles con el cobre, cuya temperatura máxima a la entrada no sobrepasa los 100°C.

La temperatura de salida de aire no debe superar los valores máximos aceptados por los ventiladores. Ver §6. El punto de congelación del fluido debe ser siempre inferior por lo menos de 5K a la temperatura invernal mínima ambiente del lugar de la instalación.

Un aerorrefrigerante estándar no puede vaciarse completamente abriendo simplemente los

orificios de purga. La instalación y el mantenimiento serán realizados por un instalador.

## Использование

**FCR NEOSTAR** : Компактный размер и высокий КПД.

**FIR NEOSTAR** : Незначительный расход заправляемого агента и высокая мощность.

Сухие охладители FC/FI NEOSTAR предназначены для кондиционирования воздуха, фрикулинга (свободного охлаждения) и охлаждения любых жидкостей, совместимых с медью, температура которых на входе не превышает 100°C.

Температура нагретого воздуха не должна превышать максимальные значения, допустимые для вентиляторов. См. § 6.

Температура замерзания жидкости всегда должна быть ниже как минимум на 5К минимальной температуры окружающего воздуха в зимний период в месте установки.

Стандартный сухой охладитель не может быть полностью опорожнен путем простого открытия сливных отверстий.

Установка и обслуживание должны выполняться профессионалом.

## **Sommaire - Summary - Zusammenfassung - Resumen - Содержание**

1.	Implantation - Lay Out - Implantacion - Установка.....	4
2.	Poids & Volumes eau - Weights & Water volumes - Gewichte und Volumen von Wasser - pesos y volúmenes de agua - Масса и объем воды .....	5
3.	Manutention - handling - Handhabung - manipulación - Погрузка и разгрузка.....	7
4.	Air vertical - Vertical air flow - Vertical luft - Aire vertical - Вертикальный выброс воздуха .....	9
4.1	Caractéristiques dimensionnelles - Dimensional characteristics - Abmessungsdaten - Características dimensionales - Размерные характеристики .....	9
4.2	Montage des pieds - Leg mounting - Fussmontage - Montaje de las patas - Монтаж ножек .....	11
	Caractéristiques électriques - Electrical data - Elektrischeangaben - Características eléctricas - Размерные характеристики .....	12
5.	Mise en Service - commissioning - Inbetriebnahme - Puesta en servicio - Ввод в эксплуатацию.....	12
6.	Raccordements électriques - Electrical connections - Elektrische Verbindungen - Conexiones eléctricas - Электрические соединения.....	13
7.1.	Raccordements moteurs - Motors connections - Motoranschlüsse - Conexionesmotores - Подключение двигателей .....	13
7.1.1	Option APC or CSB : Emplacement des boîtes à bornes - Position terminal boxes - Standort - klemmkästen - Emplazamientocajas de bornes - Размещение клеммных колодок.	14
7.2.	Moteur AC - AC motors - AC motoren - Motores AC - Двигатель переменного тока .....	14
7.2.1	Standards - Normen - Estándares - Стандарты.....	14
7.2.2	Option C2V : Câblage 2 vitesses - 2 Speed wiring - Verkabelung für 2 - Drehzahl Bereiche - Cableado 2 velocidades - Кабельное соединение для 2 скоростей.....	14
7.2.3	Option MTH : Câblage protection thermique - Thermal protection-wiring Wärmeschutzverkabelung - Cableado de protección térmica - Кабельное соединение тепловой защиты.....	15
7.2.4	Option RT/RP : Armoire de régulation - Control cabinets - Schaltschränke - Armarios de control - Шкафыуправления.....	15
7.2.5	Option CMP : Protections moteurs - Motor protections - Motorschutz - Protección del motor - Защитадвигателей.....	15
8.	Options - Optionen - Opciones - Дополнительные.....	16
8.1	VID : Vidange - Emptying - Entleeren - Vaciado - Опорожнение.....	16
8.2	PAV : Plots Anti-Vibratiles - VibrationsDampers - Schwingungsdämpfer - Amortiguadores de vibración - Противовибрационныепрокладки.....	17
8.3	REH / RE2 / RE3/ RE4 : Pieds réhaussés - Extended legs - Höhenverstellbare Füße - Patas realzadas - Поднятые ножки .....	18
8.4	ATT : Atténuateurs de bruit - Sound suppressors - Schalldämpfer - Atenuadores de ruido - Шумоглушители.....	19
9.	Entretien - Maintenance - Wartung - Mantenimiento – Обслуживание.....	20

**The English version is the original version. Existing versions in other languages are translations of the original version. In the event of a conflict of interpretation between the translated versions and the original version, the original version shall prevail.**

**1. CONSEILS D'IMPLANTATION - LAY OUT CONSIDERATIONS  
AUFSTELLUNGSEMPFEHLUNGEN - CONSEJOS DE IMPLANTACIÓN  
РЕКОМЕНДАЦИИ ПО УСТАНОВКЕ**

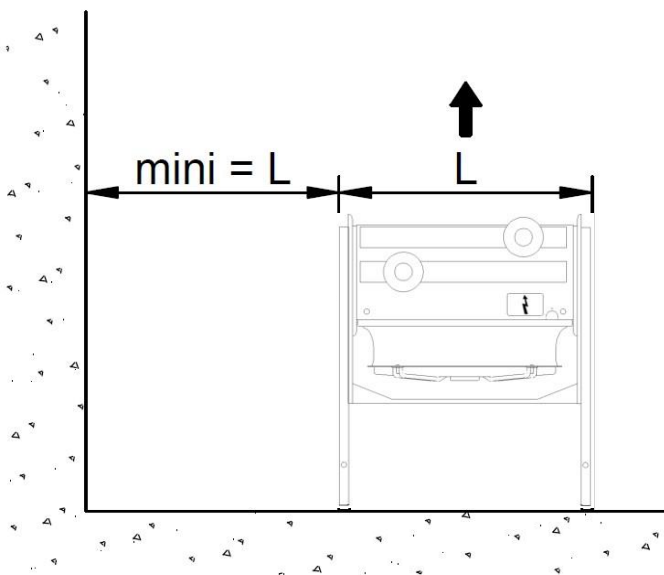

**POIDS & VOLUMES D'EAU –  
WEIGHTS & WATER VOLUMES  
GEWICHTE & VOLUMEN VON  
WASSER - PESOS & VOLUMENES  
DE AGUA - МАССА И ОБЪЕМ  
ВОДЫ**

2.

FC & FCH				FI & FIH			
Modeles	Moteurs	Volume		Modeles	Moteurs	Volume	
Models	Motors	Volumen		Modele	Motoren	Volumen	
Modelle	Motoren			Modelos	Motores		
Modelos	Motores			Modelos	Motores		
	(Nb)				(Nb)		
	(No)				(No)		
	(Anz)				(Anz)		
	(Núm.)	(dm3)	PU EC		(Núm.)	(dm3)	PU EC
... L01A1	1	18	260	... L01A2	1	36	280
... L01A2	1	30	270	... L01A3	1	42	290
... L01A3	1	36	280	... L01A4	1	48	300
... L01A4	1	40	290	... L01A5	1	49	310
... L01B1	1	21	280	... L01B2	1	40	300
... L01B2	1	34	290	... L01B3	1	47	310
... L01B3	1	40	300	... L01B4	1	55	330
... L01B4	1	45	320	... L01B5	1	57	340
... L01D1	1	24	300	... L01D2	1	47	330
... L01D2	1	39	320	... L01D3	1	56	350
... L01D3	1	47	330	... L01D4	1	66	370
... L01D4	1	54	350	... L01D5	1	71	390
... L02A1	2	27	390	... L02A2	2	53	420
... L02A2	2	43	410	... L02A3	2	64	450
... L02A3	2	52	430	... L02A4	2	76	470
... L02A4	2	61	450	... L02A5	2	83	490
... L02B1	2	31	420	... L02B2	2	61	460
... L02B2	2	49	450	... L02B3	2	76	490
... L02B3	2	61	470	... L02B4	2	90	520
... L02B4	2	72	500	... L02B5	2	99	550
... L02D1	2	38	500	... L02D2	2	75	560
... L02D2	2	60	530	... L02D3	2	94	590
... L02D3	2	75	570	... L02D4	2	113	630
... L02D4	2	89	600	... L02D5	2	127	670
... L03A1	3	35	550	... L03A2	3	70	600
... L03A2	3	56	580	... L03A3	3	87	640
... L03A3	3	69	610	... L03A4	3	104	670
... L03A4	3	82	650	... L03A5	3	116	710
... L03B1	3	42	600	... L03B2	3	82	660
... L03B2	3	65	640	... L03B3	3	104	710
... L03B3	3	82	680	... L03B4	3	125	750
... L03B4	3	98	710	... L03B5	3	142	790
... L03D1	3	52	700	... L03D2	3	103	780
... L03D2	3	81	750	... L03D3	3	131	840
... L03D3	3	103	800	... L03D4	3	159	900
... L03D4	3	124	850	... L03D5	3	182	960
... L04A1	4	44	680	... L04A2	4	87	750
... L04A2	4	68	720	... L04A3	4	110	790
... L04A3	4	86	760	... L04A4	4	133	840
... L04A4	4	103	800	... L04A5	4	150	890
... L04B1	4	52	740	... L04B2	4	104	830
... L04B2	4	81	790	... L04B3	4	132	880
... L04B3	4	103	840	... L04B4	4	161	940
... L04B4	4	124	890	... L04B5	4	184	1000
... L04D1	4	66	910	... L04D2	4	131	1020
... L04D2	4	102	980	... L04D3	4	168	1100
... L04D3	4	131	1040	... L04D4	4	206	1180
... L04D4	4	159	1110	... L04D5	4	238	1250
... L05A1	5	52	840	... L05A2	5	104	930
... L05A2	5	81	900	... L05A3	5	132	990
... L05A3	5	103	950	... L05A4	5	161	1050
... L05A4	5	124	1000	... L05A5	5	184	1110
... L05B1	5	63	930	... L05B2	5	125	1040
... L05B2	5	97	1000	... L05B3	5	160	1110
... L05B3	5	124	1060	... L05B4	5	196	1180
... L05B4	5	150	1120	... L05B5	5	227	1260
... L06A1	6	60	990	... L06A2	6	121	1090
... L06A2	6	93	1050	... L06A3	6	155	1160
... L06A3	6	120	1110	... L06A4	6	189	1230
... L06A4	6	145	1170	... L06A5	6	218	1300

FC & FCH

FI & FIH

Modeles Models Modelle Modelos	Moteurs Motors Motoren Motores (Nb) (No) (Anz) (Núm.)	Volume Volumen		Modeles Models Modelle Modelos	Moteurs Motors Motoren Motores (Nb) (No) (Anz) (Núm.)	Volume Volumen	
		(dm3)	PU EC			(dm3)	PU EC
... P02A1	2	53	400	... P10A1	10	120	1390
... P02A2	2	63	420	... P10A2	10	164	1490
... P02A3	2	84	440	... P10A3	10	219	1590
... P02A4	2	91	470	... P10A4	10	259	1690
... P02B1	2	57	430	... P10B1	10	141	1540
... P02B2	2	69	450	... P10B2	10	196	1660
... P02B3	2	93	480	... P10B3	10	261	1780
... P02B4	2	101	500	... P10B4	10	311	1910
... P02D1	2	64	470	... P10D1	10	176	1810
... P02D2	2	80	500	... P10D2	10	248	1980
... P02D3	2	107	540	... P10D3	10	331	2140
... P02D4	2	119	570	... P10D4	10	399	2300
... P04A1	4	70	630	... P12A1	12	137	1640
... P04A2	4	88	670	... P12A2	12	189	1760
... P04A3	4	118	710	... P12A3	12	253	1870
... P04A4	4	133	750	... P12A4	12	301	2000
... P04B1	4	78	680	... P12B1	12	162	1830
... P04B2	4	101	730	... P12B2	12	227	1980
... P04B3	4	135	780	... P12B3	12	303	2130
... P04B4	4	154	830	... P12B4	12	364	2280
... P04D1	4	92	800	... P12D1	12	204	2150
... P04D2	4	122	870	... P12D2	12	290	2340
... P04D3	4	163	930	... P12D3	12	387	2540
... P04D4	4	189	1000	... P12D4	12	469	2740
... P06A1	6	87	900	... P14A1	14	154	1910
... P06A2	6	114	960	... P14A2	14	214	2040
... P06A3	6	152	1010	... P14A3	14	286	2180
... P06A4	6	175	1080	... P14A4	14	343	2320
... P06B1	6	99	980	... P14B1	14	183	2130
... P06B2	6	133	1050	... P14B2	14	259	2300
... P06B3	6	177	1120	... P14B3	14	345	2470
... P06B4	6	206	1200	... P14B4	14	416	2650
... P06D1	6	120	1130	... P16A1	16	171	2140
... P06D2	6	164	1230	... P16A2	16	240	2300
... P06D3	6	219	1330	... P16A3	16	320	2460
... P06D4	6	259	1430	... P16A4	16	385	2620
... P08A1	8	103	1130	... P16B1	16	204	2390
... P08A2	8	139	1210	... P16B2	16	290	2590
... P08A3	8	185	1280	... P16B3	16	387	2780
... P08A4	8	217	1370	... P16B4	16	469	2980
... P08B1	8	120	1230				
... P08B2	8	164	1330				
... P08B3	8	219	1430				
... P08B4	8	259	1530				
... P08D1	8	148	1470				
... P08D2	8	206	1610				
... P08D3	8	275	1740				
... P08D4	8	329	1870				

Modeles Models Modelle Modelos	Moteurs Motors Motoren Motores (Nb) (No) (Anz) (Núm.)	Volume Volumen		Modeles Models Modelle Modelos	Moteurs Motors Motoren Motores (Nb) (No) (Anz) (Núm.)	Volume Volumen	
		(dm3)	PU EC			(dm3)	PU EC
... P02A2	2	92	470	... P10A2	10	228	1590
... P02A3	2	105	510	... P10A3	10	286	1730
... P02A4	2	119	540	... P10A4	10	345	1850
... P02A5	2	134	560	... P10A5	10	405	1970
... P02B2	2	101	500	... P10B2	10	268	1770
... P02B3	2	115	550	... P10B3	10	339	1940
... P02B4	2	133	580	... P10B4	10	412	2090
... P02B5	2	151	610	... P10B5	10	486	2240
... P02D2	2	114	560	... P10D2	10	341	2120
... P02D3	2	134	620	... P10D3	10	436	2330
... P02D4	2	153	660	... P10D4	10	530	2530
... P02D5	2	172	700	... P10D5	10	625	2730
... P04A2	4	126	730	... P12A2	12	262	1870
... P04A3	4	150	800	... P12A3	12	331	2030
... P04A4	4	175	850	... P12A4	12	401	2180
... P04A5	4	202	890	... P12A5	12	473	2320
... P04B2	4	143	800	... P12B2	12	310	2110
... P04B3	4	172	880	... P12B3	12	394	2300
... P04B4	4	203	940	... P12B4	12	482	2490
... P04B5	4	236	1000	... P12B5	12	570	2660
... P04D2	4	170	940	... P12D2	12	397	2510
... P04D3	4	209	1040	... P12D3	12	512	2760
... P04D4	4	246	1120	... P12D4	12	624	3000
... P04D5	4	284	1200	... P12D5	12	738	3240
... P06A2	6	160	1030	... P14A2	14	296	2170
... P06A3	6	195	1120	... P14A3	14	376	2350
... P06A4	6	232	1200	... P14A4	14	458	2530
... P06A5	6	270	1260	... P14A5	14	541	2690
... P06B2	6	185	1130	... P14B2	14	352	2450
... P06B3	6	228	1240	... P14B3	14	450	2670
... P06B4	6	274	1330	... P14B4	14	552	2880
... P06B5	6	321	1420	... P14B5	14	654	3090
... P06D2	6	226	1330	... P16A2	16	329	2440
... P06D3	6	284	1470	... P16A3	16	421	2640
... P06D4	6	339	1590	... P16A4	16	514	2840
... P06D5	6	395	1700	... P16A5	16	609	3030
... P08A2	8	194	1290	... P16B2	16	394	2750
... P08A3	8	241	1400	... P16B3	16	506	3000
... P08A4	8	288	1510	... P16B4	16	621	3240
... P08A5	8	338	1600	... P16B5	16	738	3480
... P08B2	8	226	1430	... P18A2	18	363	2740
... P08B3	8	283	1560	... P18A3	18	467	2970
... P08B4	8	342	1690	... P18A4	18	571	3190
... P08B5	8	402	1800	... P18A5	18	676	3400
... P08D2	8	282	1720	... P20A2	20	397	3010
... P08D3	8	358	1900	... P20A3	20	512	3260
... P08D4	8	432	2060	... P20A4	20	627	3510
... P08D5	8	507	2220				

### 3. POINTS DE MANUTENTION - LIFTING LOCATIONS AUFHÄNGUNGSPUNKTE - LOCALIZACIONES DE ELEVACION - ТОЧКИ КРЕПЛЕНИЯ ПРИ ПОГРУЗКЕ/РАЗГРУЗКЕ

POIDS NET	Voir §2
NET WEIGHT	See §2
NETTOGEWICHT	Siehe §2
PESONETO	Ver §2
HETTO	Ver §2

L01-A.B.D / P02-A.B.D

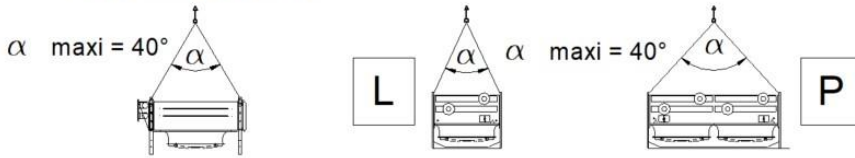

A = 1.2 M
B = 1.5 M
D = 2 M

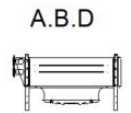

L02-A.B.D / P04-A.B.D

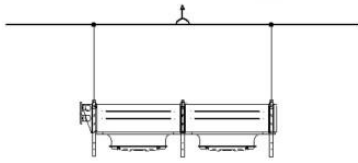

L03-A.B / P06-A.B

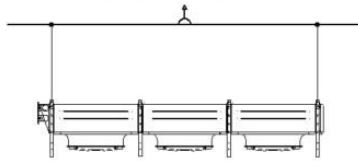

L03-D / P06-D

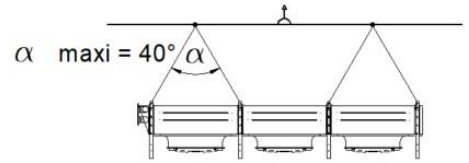

L06-A / P12-A.B

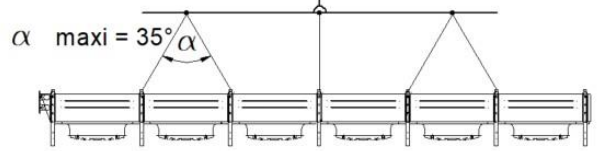
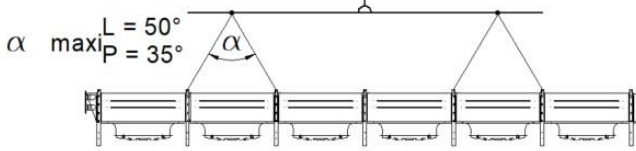

P14-A

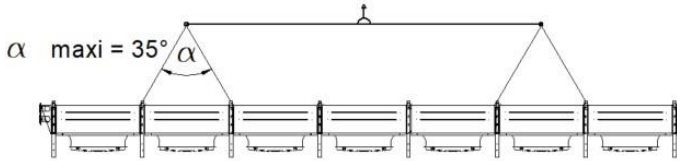

L05-A.B

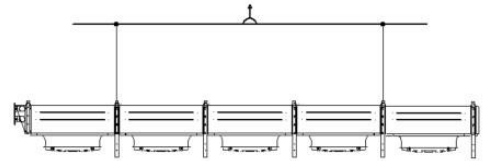

P14-B P18-A

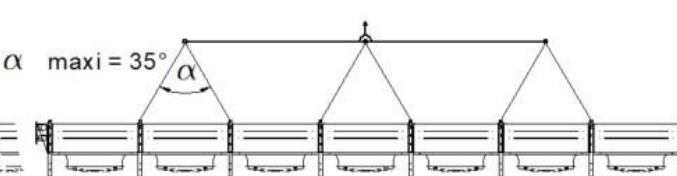

P10-A.B.D

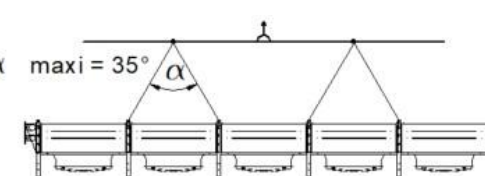

P16-A

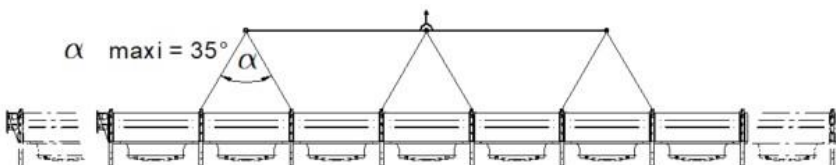

L04-A.B.D / P08-A.B

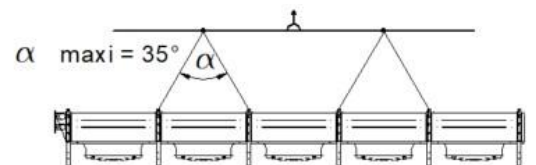

$\alpha_{\text{maxi}} = 35^\circ$

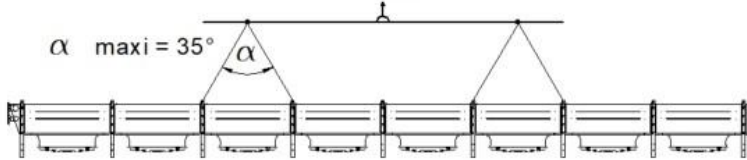

P16-B

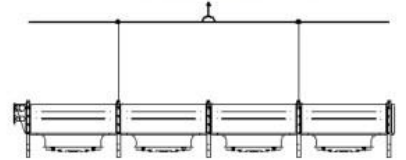

P08-D

$\alpha_{\text{maxi}} = 50^\circ$

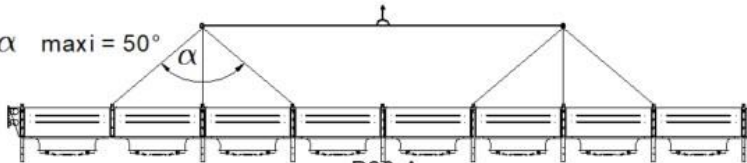

P20-A

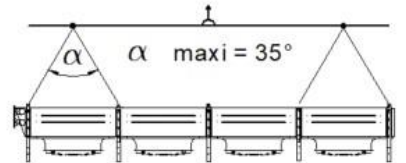

$\alpha_{\text{maxi}} = 45^\circ$

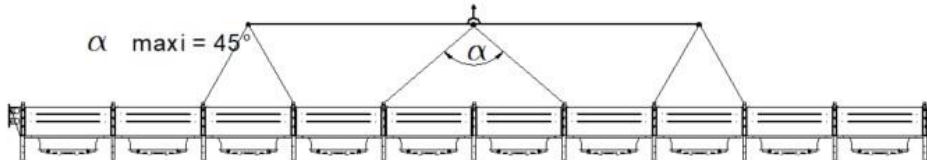

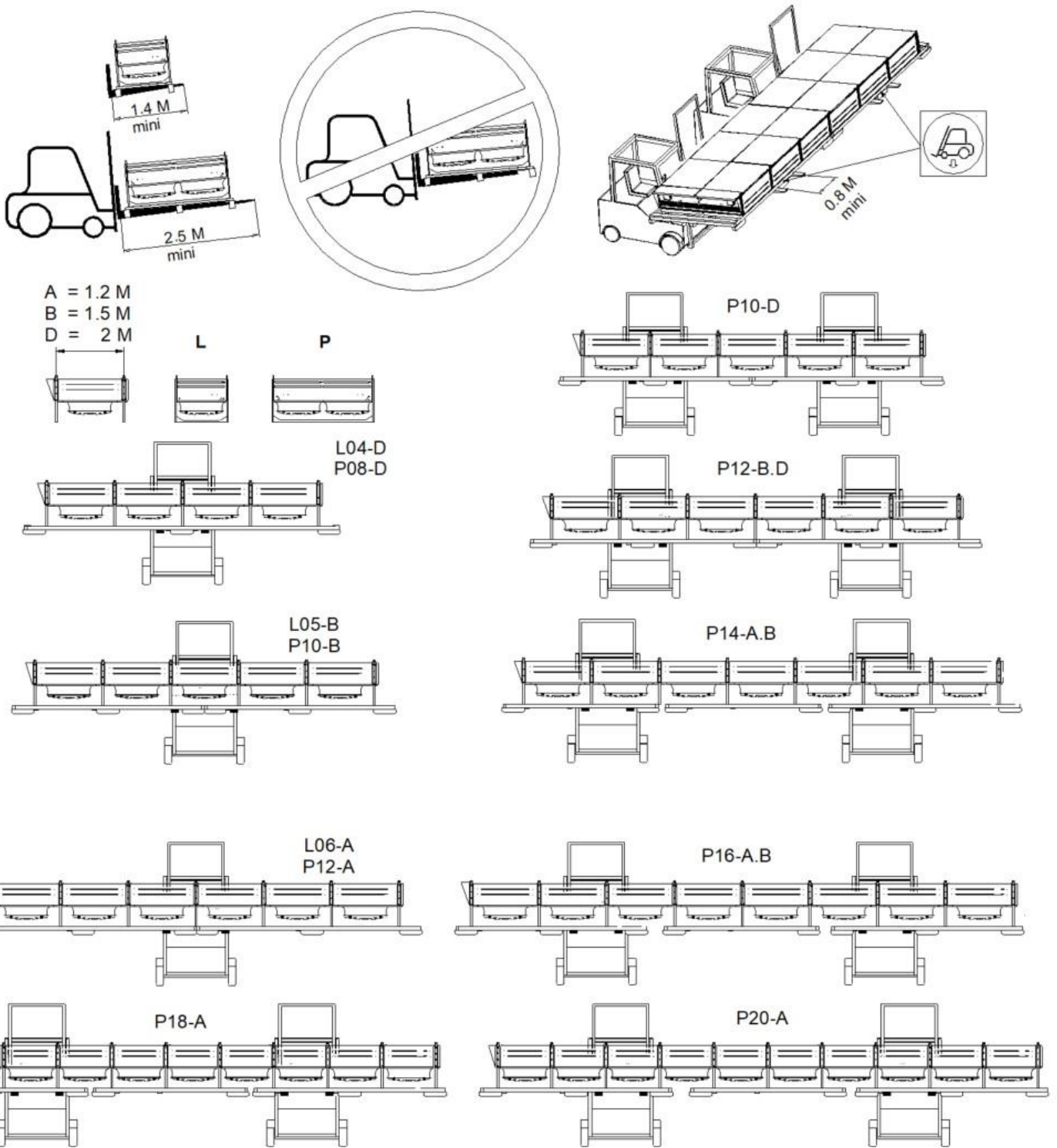

#### 4. AIR VERTICAL - VERTICAL AIR FLOW - VERTICAL LUFT - AIRE VERTICAL - (TRADUCTION RUSSE)

##### 4.1 Caractéristiques dimensionnelles - Dimensional characteristics - Abmessungsdaten

# - Características dimensionales - Размерные характеристики

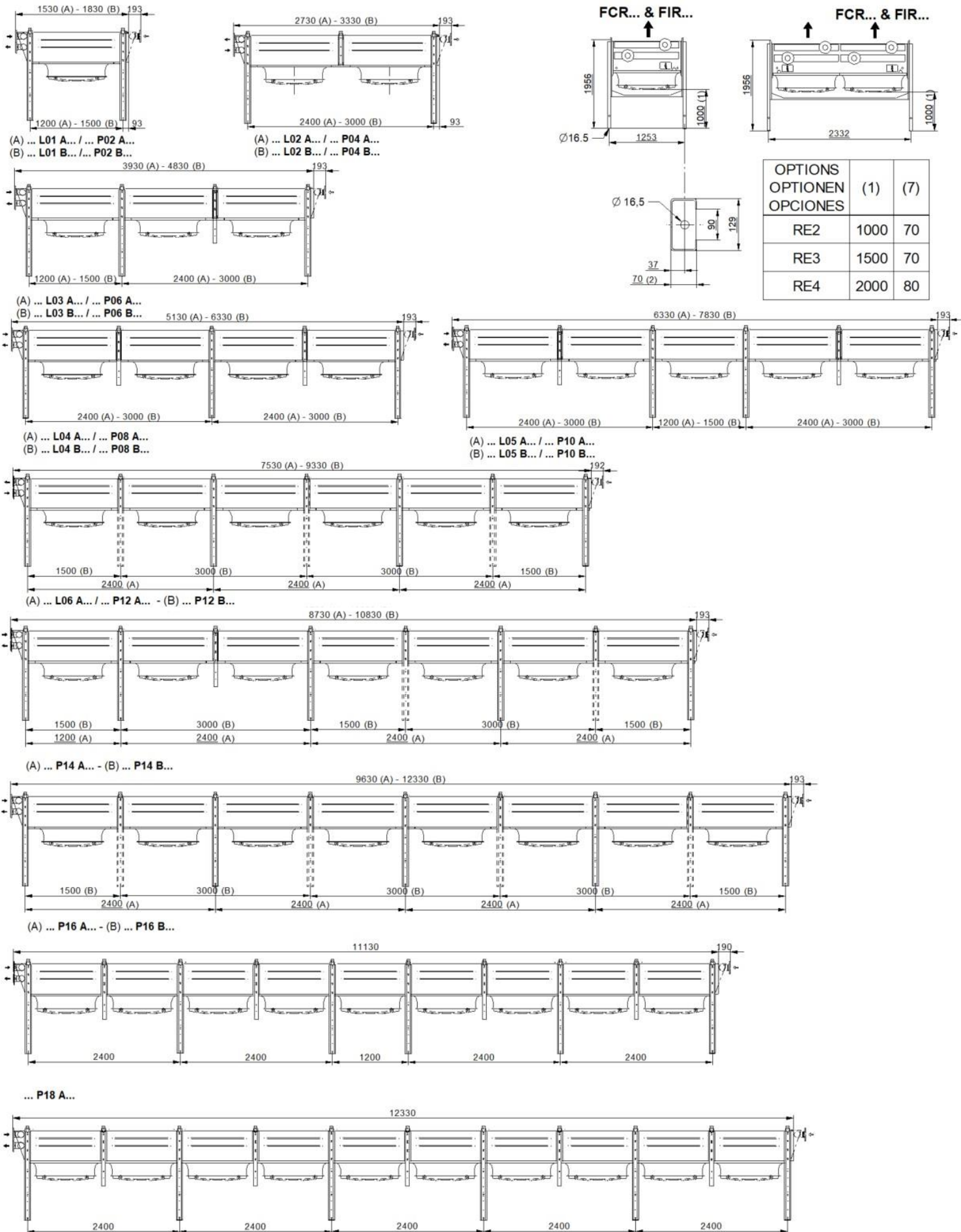

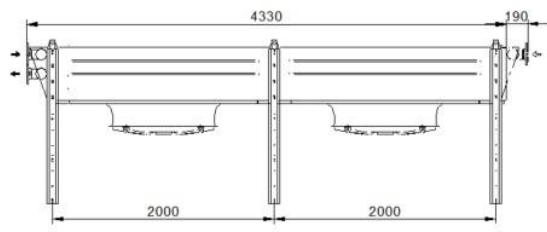

... L02 D... / ... P04 D...

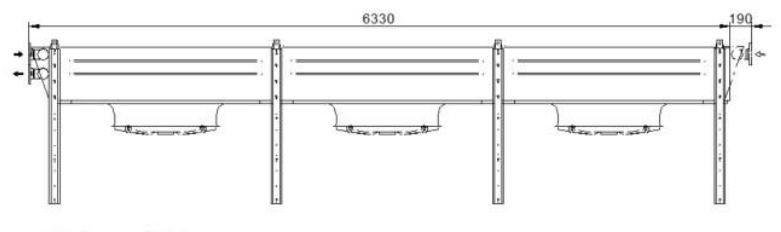

... L03 D... / ... P06 D...

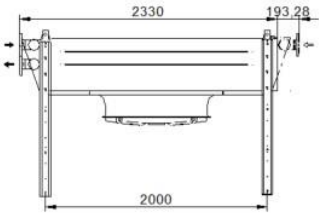

... L01 D... / ... P02 D...

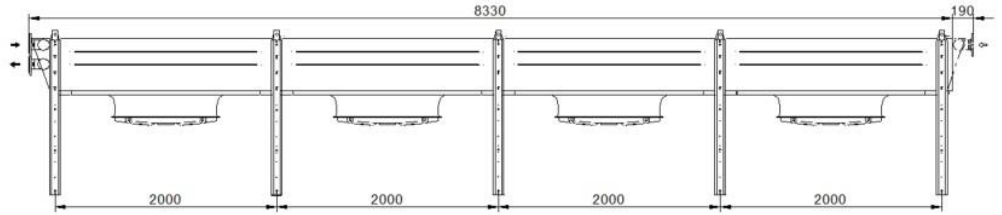

... L04 D... / ... P08 D...

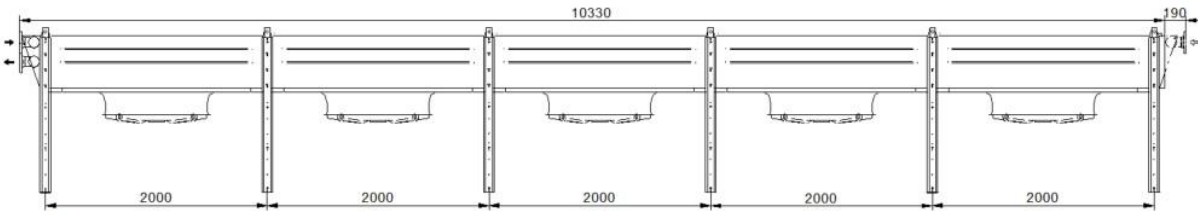

... P10 D...

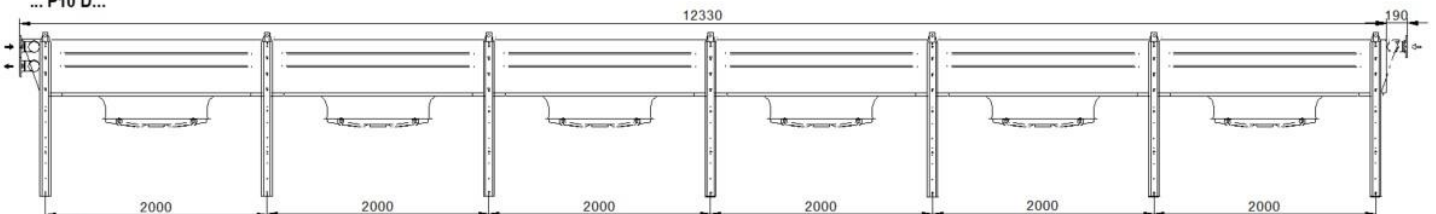

... P12 D...

## 4.2 Montage des pieds - Leg mounting - Fussmontage - Montaje de las patas - Монтаж

ножек

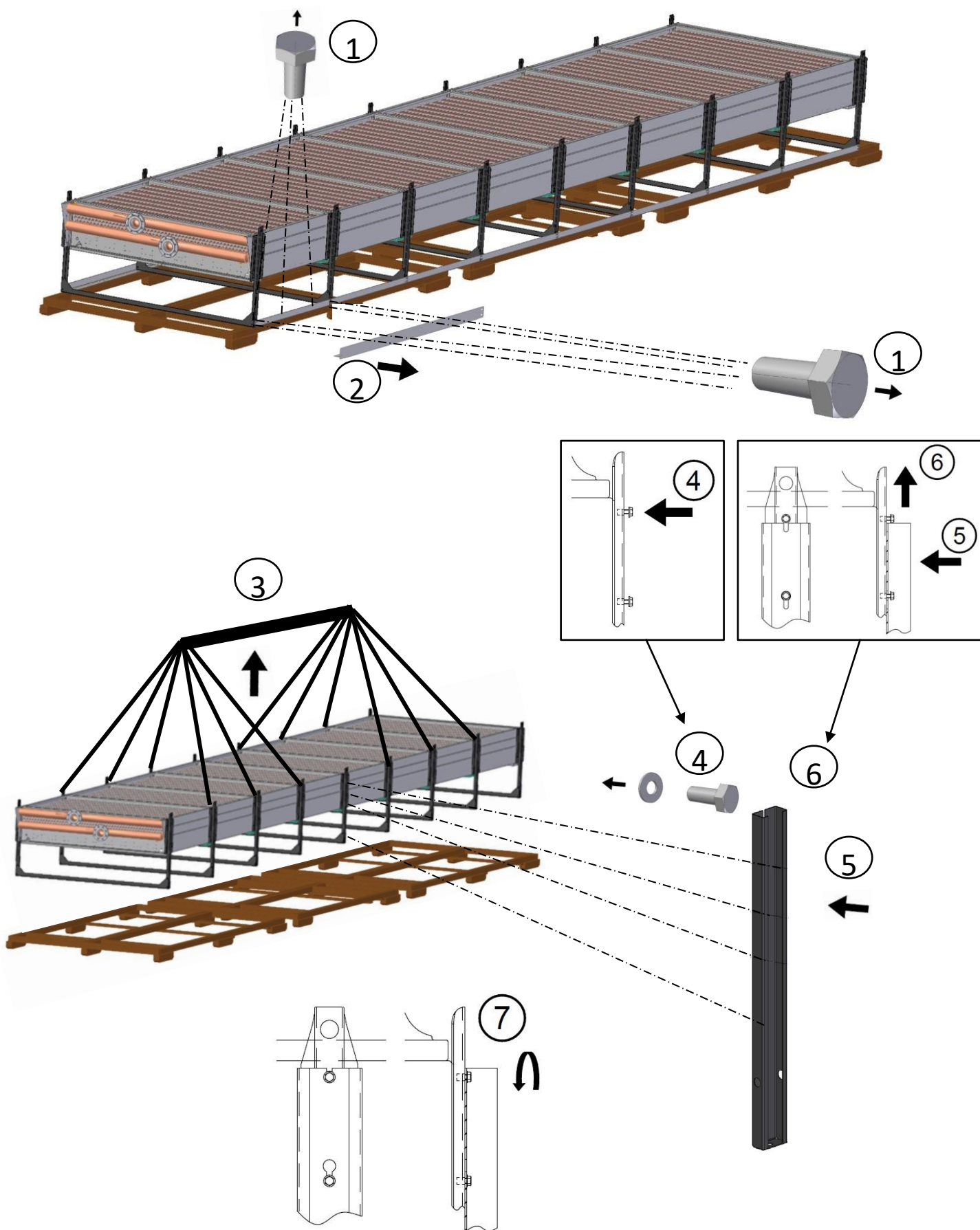

## 5. CARACTERISTIQUES ELECTRIQUES - ELECTRICAL CONNECTIONS - ELEKTRISCHE VERBINDUNGEN - CONEXIONES ELECTRICAS - ЭЛЕКТРИЧЕСКИЕ СОЕДИНЕНИЯ

- Réglage des protections contre les surcharges. Pour des températures d'air "ti" autres que +20 °C, multiplier les intensités par le rapport  $293/(273 + "ti")$ .
- Setting of overload protection levels. For air temperatures "ti" other than +20 °C, multiply the currents in relation to  $293/(273 + "ti")$ .
- Einstellung des Überlastschutzes. Für andere Lufttemperaturzustände "ti" als +20 °C wird die Stromstärke mit einem Verhältnis  $293/(273 + "ti")$  multipliziert.
- Regulación de las protecciones contra las sobrecargas. Para temperaturas de aire "ti" que no sean +20 °C, multiplicar las intensidades por la relación  $293/(273 + "ti")$ .
- Настройка защиты от перегрузок. Для температур воздуха "ti", отличных от +20 °C, умножить интенсивность по формуле  $293/(273 + "ti")$ .

Type	D	Delta (Ti = 20°C)	Star (Ti = 20°C)	Max Temp.
PM04D/Y	910	5400W max. - 9A max. - (1230rpm-U/min)	3200W max. - 5.2A max. - (900rpm-U/min)	40°C - 60°C
PU06D/Y	910	2480W max. - 5.15A max. - (885rpm-U/min)	1570W max. - 2.9A max. - (685rpm-U/min)	60°C
PN06D/Y	800	1940W max. - 3.9A max. - (880rpm-U/min)	1210W max. - 2.23A max. - (670rpm-U/min)	70°C - 75°C - 80°C
SN08D/Y	800	890W max. - 2.22A max. - (680rpm-U/min)	590W max. - 1.17A max. - (540rpm-U/min)	80°C
SE12D/SU12Y	800	320W max. - 0.84A max. - (440rpm-U/min)	190W max. - 0.39A max. - (330rpm-U/min)	80°C
SU 16Y	800	X	100W max. - 0.25A max. - (250rpm-U/min)	80°C
H PU06D/Y	910	1950W max. - 4.2A max. - (890rpm-U/min)	1300W max. - 2.3A max. - (730rpm-U/min)	80°C
H SN08D/Y	910	880W max. - 2A max. - (150rpm-U/min)	500W max. - 1.05A max. - (480rpm-U/min)	80°C
SE EC	800	2560W max. - 3.9A max. - (1020rpm-U/min)	-	60°C
SU EC	800	835W max. - 1.4A max. - (735rpm-U/min)	-	60°C
PU EC	910	3040W max. - 4.9A max. - (1195rpm-U/min)	-	60°C
PU EC	800	3000W max. - 4.5A max. - (1200rpm-U/min)	-	<= 1000tr/mn - 70°C 1000tr/mn < 40°C < 1200tr/mn

## 6. MISE EN SERVICE - START UP - INBETRIEBNAHME - PUESTA EN SERVICIO - ВВОД В ЭКСПЛУАТАЦИЮ

- Variateur de fréquence uniquement possible avec un filtre sinus LC tout pole, sinon la garantie moteurs est invalidée.
- Frequency inverter only possible with a sinus LC filter all pole, otherwise the motor warranty is invalidated.
- Frequenzumformers nur mit allpoligen LC Sinusfilter möglich, ansonsten erlöscht die Gewährleistung auf die Motoren.
- El inversor de frecuencia solo es posible con un filtro sinusoidal LC todos los polos, de lo contrario, la garantía del motor queda invalidada.
- Использование вариатора частоты возможно только с синусным фильтром LC на всех полюсах, в противном случае гарантия на двигатели не распространяется.



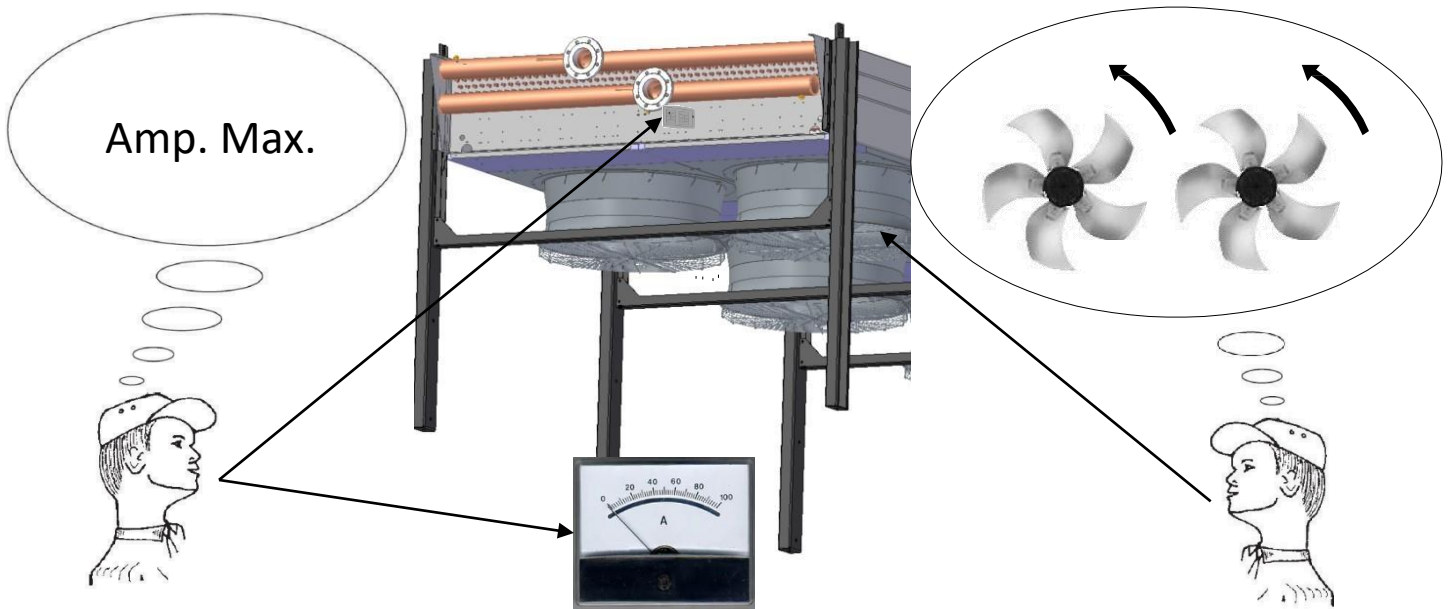

## 7. RACCORDEMENTS ELECTRIQUES - ELECTRICAL CONNECTIONS - ELEKTRISCHE ANSCHLÜSSE CONEXIONESELÉTRICAS - ЭЛЕКТРИЧЕСКИЕ СОЕДИНЕНИЯ

ATTENTION : Couper l'alimentation avant toute intervention (Opération effectuée par un personnel habilité et qualifié)



WARNING : Isolate the power supply before working on the appliance (Operation performed by qualified persons)

ACHTUNG : Vor jedem Eingriff Strom abschalten (Der Betrieb von qualifizierten Personen durchgeführt)

PRECAUCIÓN : Corten la alimentación eléctrica antes de trabajar (Operación realizada por personas calificadas)

ВНИМАНИЕ : Перед выполнением любых работ обязательно отключайте питание (Работы должны выполняться квалифицированным специалистом)

### 7.1 Raccordements moteurs - Motor connections - Motoranschlüsse - Conexiones motores - Подключение двигателей

FCR & FIR



FCRH & FIRH

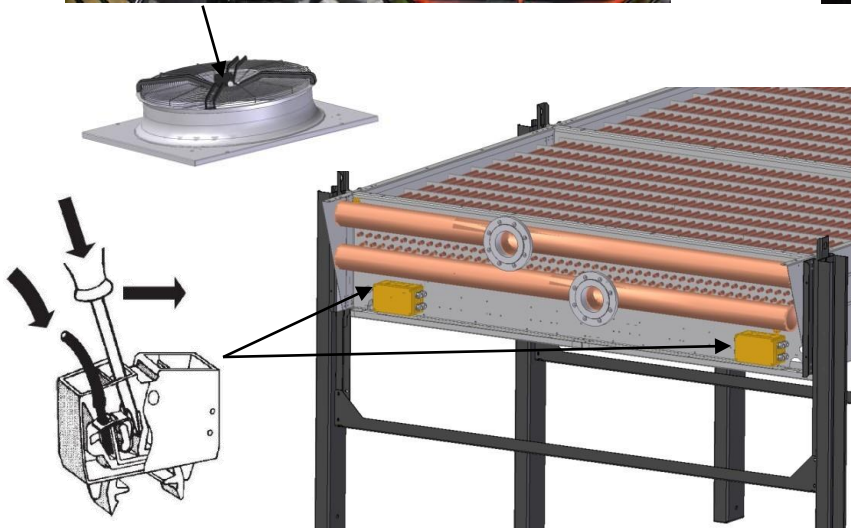
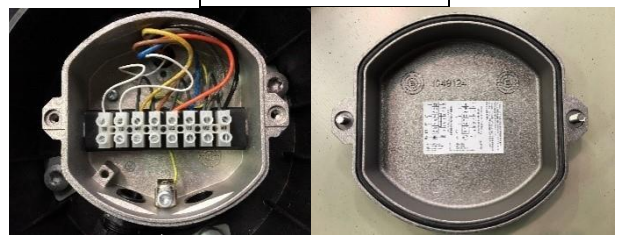

FCR EC & FIR EC

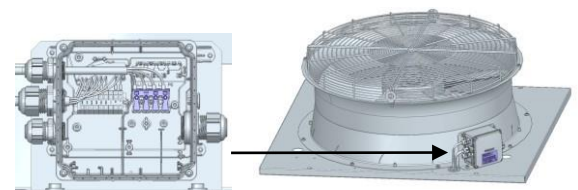

**7.1.1 Option APC or CSB : Emplacement des boîtes à bornes - Position terminal boxes - Standort klemmkästen - Emplazamiento cajas de bornes - Размещение клеммных колодок**

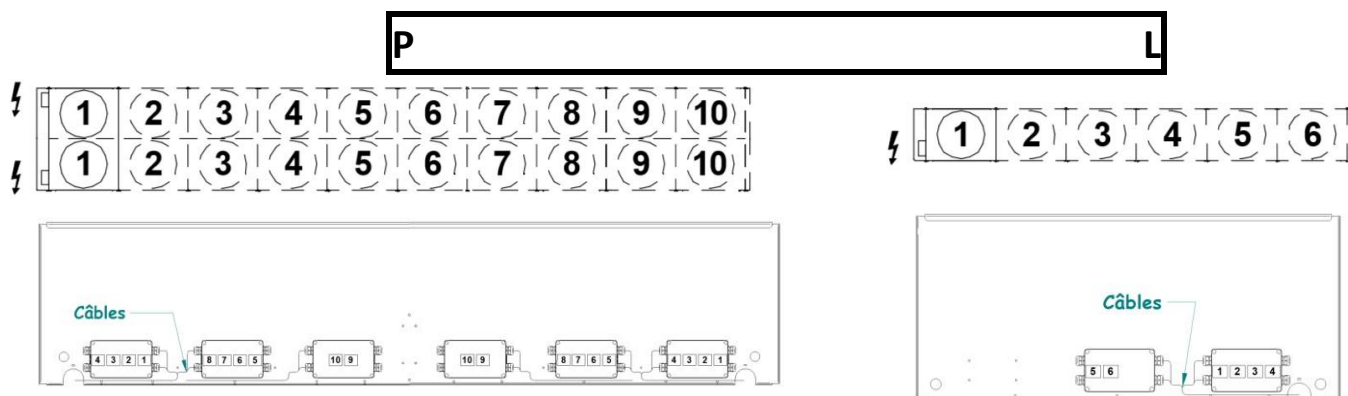

**7.2 Moteur AC - AC motors - AC motoren - Motores AC - Двигатель переменного тока**

**7.2.1 Standards - Normen - Estándares - Стандарты**

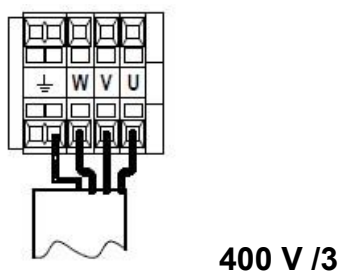

**7.2.2 Option C2V : Câblage 2 vitesses - 2 Speed wiring - Verkabelung für 2 - Drehzahl Bereiche - Cableado 2 velocidades - Кабельное соединение для 2 скоростей**

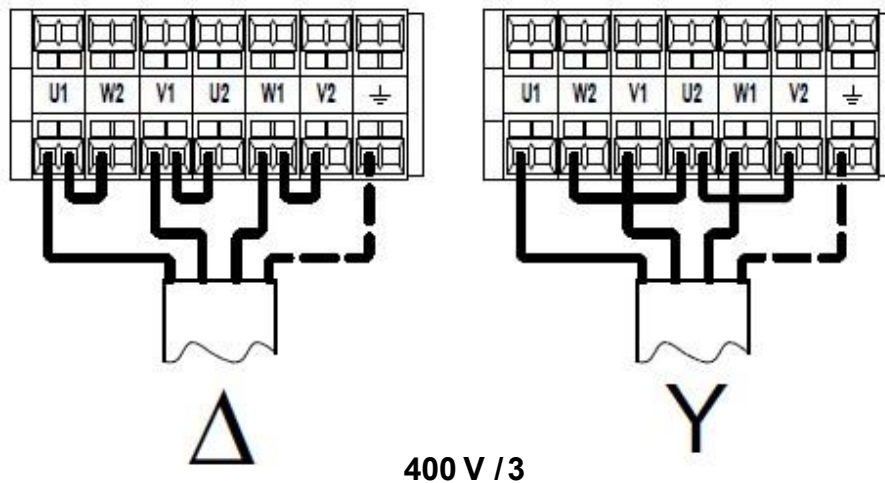

**7.2.3 Option MTH : Câblage protection thermique - Thermal protection-wiring -**

Wärmeschutzverkabelung - Cableado de protección térmica - Кабельное соединение тепловой защиты

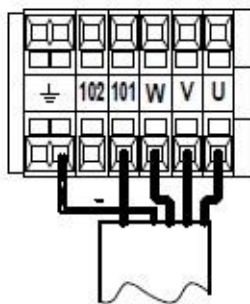

400 V /3

7.2.4 Option EC : Notice technique d'installation – Installation instructions – Installationsnotiz – Manual tecnico de instalacion - Техническое руководство по установке : IN0034700

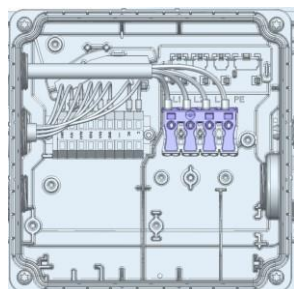

## 7.2.4 Option RT/RP : Armoire de régulation - Control cabinets - Schaltschränke - Armarios de control - Шкафы управления

X= Armoire de régulation livrée séparément  
 X= Control cabinet delivered separately  
 X= Schaltschrank wird separat geliefert  
 X= Gabinete de control entregado por separado  
 X= Шкафы управления поставляются отдельно

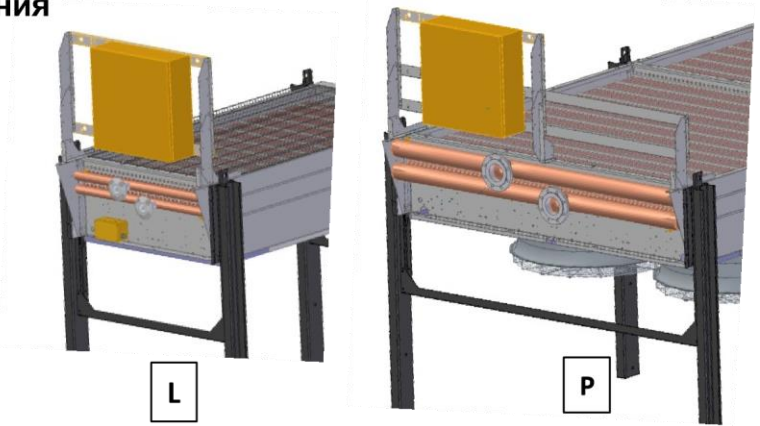

	Poids - Weight - Gewicht - Peso (kg)										
	RT1 / RP1		RT2 / RP2				RT3 / RP3				
Moteurs Motors Motoren Motores	PU06D	PU06Y	PU06D	PU06Y	SN08Y	SU12Y	PU06D	PU06Y	SN08Y	SU12Y	SU16Y
Modèles Models Modelle Modelos	PN06D	PN06Y	PN06D	PN06Y	SE12D	SU16Y	PN06D	PN06Y	SE12D		
	HPU06D	SN08D/Y	HPU06D	SN08D	HSN08Y		HPU06D	SN08D	HSN08Y		
		SE12D		HPU06Y				HPU06Y			
		SU12Y		HSN08D				HSN08D			
		SU16Y									
		HPU06Y									
		HSN08D/Y									
... L01..	+ 31	+ 24	+ 30	+ 30	+ 30	+ 30	+ 40	+ 40	+ 38	+ 38	+ 38
... L02..	+ 31	+ 35	+ 31	+ 30	+ 30	+ 30	+ 45	+ 42	+ 38	+ 38	+ 38
... L03..	+ 32	+ 36	+ 31	+ 31	+ 30	+ 31	+ 67	+ 45	+ 40	+ 38	+ 38
... L04..	+ 32	+ 42	+ 36	+ 31	+ 31	+ 31	+ 71	+ 55	+ 40	+ 38	+ 38
... L05..	+ 36	+ 43	+ 38	+ 32	+ 32	+ 32	+ 76	+ 68	+ 43	+ 39	+ 39
... L06..	+ 36	+ 44	+ 38	+ 38	+ 32	+ 32	+ 96	+ 72	+ 46	+ 41	+ 39
... P04..	+ 34	+ 27	+ 34	+ 33	+ 33	+ 33	+ 48	+ 45	+ 41	+ 41	+ 41
... P04..	+ 35	+ 45	+ 39	+ 34	+ 34	+ 34	+ 74	+ 58	+ 43	+ 41	+ 41
... P06..	+ 38	+ 45	+ 40	+ 40	+ 34	+ 34	+ 98	+ 74	+ 43	+ 43	+ 41
... P08..	+ 46	+ 46	+ 68	+ 53	+ 47	+ 36	+ 121	+ 79	+ 59	+ 57	+ 54
... P10..	+ 57	+ 57	+ 84	+ 54	+ 48	+ 48	X	+ 99	+ 61	+ 57	+ 57
... P12..	+ 71	+ 71	+ 85	+ 79	+ 57	+ 58	X	+ 121	+ 61	+ 59	+ 57
... P14..	+ 71	+ 71	+ 103	+ 80	+ 64	+ 59	X	+ 121	+ 61	+ 59	+ 57
... P16..	+ 72	+ 72	+ 109	+ 86	+ 65	+ 59	X	X	+ 71	+ 61	+ 57
... P18..	+ 80	+ 80	+ 121	+ 99	+ 75	+ 70	X	X	+ 82	+ 67	+ 63
... P20..	+ 81	+ 81	+ 161	+ 100	+ 76	+ 71	X	X	+ 82	+ 67	+ 63

## 7.2.5 Option CMP: Protections moteurs - Motor protections - Motorschutz - Protección del motor - Защита двигателей

L

Modeles Models	Poids Weight	Modeles Models	Poids Weight
-------------------	-----------------	-------------------	-----------------

P

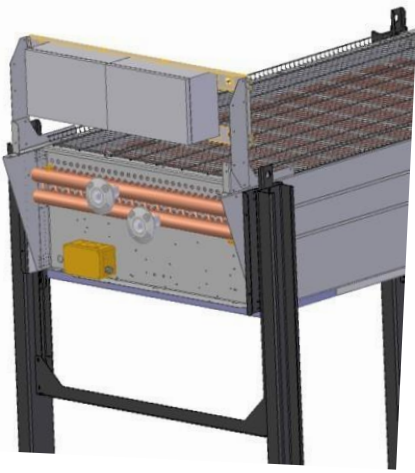

Modelle Modelos	Gewicht Peso (kg)	Modelle Modelos	Gewicht Peso (kg)
..L01..	+ 13	..P02..	+ 14
..L02..	+ 14	..P04..	+ 15
..L03..	+ 14	..P06..	+ 20
..L04..	+ 15	..P08..	+ 21
..L05..	+ 16	..P10..	+ 23
..L06..	+ 20	..P12..	+ 24
		..P14..	+ 26
		..P16..	+ 31
		..P18..	+ 43
		..P20..	+ 45

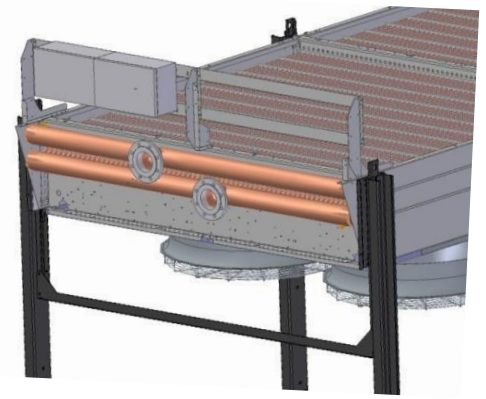

## 8. AUTRES OPTIONS - OTHERS OPTIONS - ANDERE PTIONEN - OTRAS OPCIONES - ДОПОЛНИТЕЛЬНЫЕ ОПЦИИ

**8.1 VID : Installation d'appareils circuités spécifiquement pour une vidange gravitaire -  
installation von geräten mit spezifischen kreisen zur voll entleerung - Durch  
schwerkraft ablauf - Installation for units with special circuits allowing a full  
drainability through gravity - установка устройтво, специально  
предназначенных для гравитационного слива**

- Eau sans glycol et zone de gel : circuit special avec vidange gravitaire + position inclinee
- Plain water and frost risk : special circuiting with gravity drain + sloped installation
- Glykolfreiem wasser und frostgefahr : spezialkreislauf mit schwerkraftablauf + geneigte position
- Agua no glicolado y zona de hielo : circuito especial con drenaje por gravedad + posicion inclinada
- Вода без гликоля и зоны замораживания: специальный контур для гравитационного слива + наклоненное положение

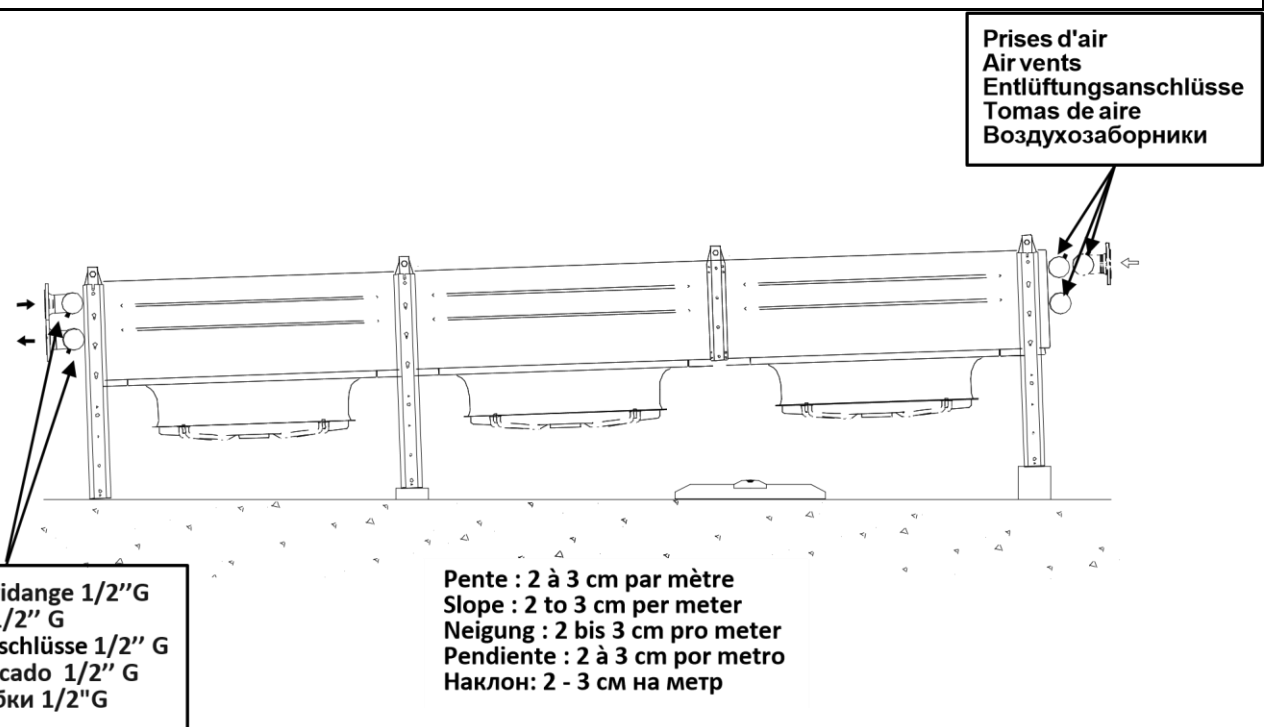

- **VIDANGE** En cas de Température d'air < +5°C : retirer tous les bouchons, vidanges et prises d'air, et s'assurer de l'écoulement total.
- **DRAINING** (Air temperature >+5°C) : take off all plugs, drains and vents, and make sure of full draining.
- **ENTLEERUNG** (Lufttemperatur >+5°C) : alle entleerungs und entlüftungsanschlüsse öffnen und vollständige leerung sicherstellen.
- **VACIADO** (Temperatura del aire >+5°C) : retirar todos los tapones, vaciados y tomas des aire,y cerciorarse deldesagüe total.
- **СЛИВ** (Температура воздуха >+5°C): снимите все пробки, дренажи и воздухозаборники и убедитесь, что из устройства вытекла вся жидкость.

## 8.2 PAV : Plots Anti-Vibratiles - Vibrations Dampers - Schwingungsdämpfer - Amortiguadores de vibración - Противовибрационные прокладки

PAV	A	B	B1	C	D	E	F	M	Kg
PI9M00001 - APK T 100/60	100	27,5	25,5	10,2	124	10,2	148	22	0,46
PI9M00005 - APK T 100/75	100	27,5	25,5	10,2	124	10,2	148	22	0,46
PI9M00002 - APK T 150/60	150	39	36	14,2	182	12,2	214	34	1,34
PI9M00003 - APK T 150/75	150	39	36	14,2	182	12,2	214	34	1,34
PI9M00004 - APK T 200/45	200	44	40	18	240	14,5	280	44	3,03

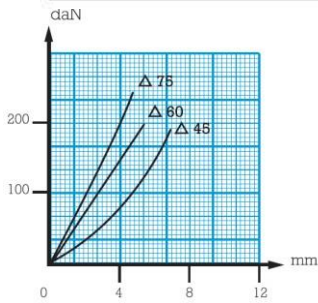

APK T 100

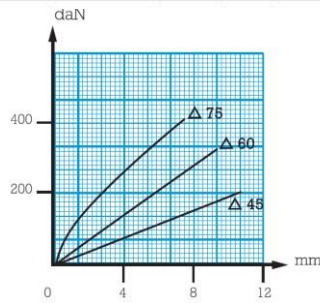

APK T 150

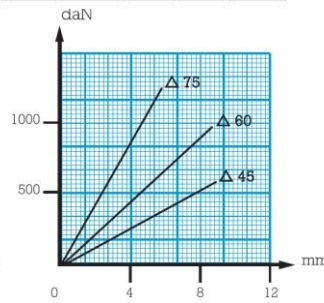

APK T 200

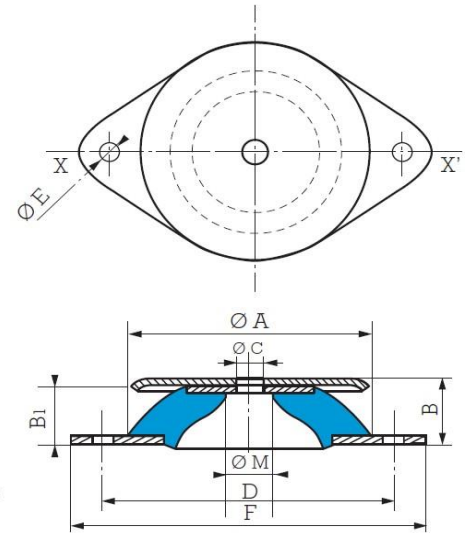

**Valable uniquement avec soufflage vertical - Applies only with vertical blowing - Nur gültig bei vertikalem Auslass - Válido solo con descarga vertical - Действительно только применительно к варианту с вертикальным направлением воздуха**

FC															
Modèles Models Modelle Modelos	L01			L02			L03			L04			L05		L06
	A	B	D	A	B	D	A	B	D	A	B	D	A	B	A
PI9M00001 - APK T 100/60	4	4	4												
PI9M00005 - APK T 100/75				4	4	4	6	6	8						
PI9M00002 - APK T 150/60										6	6	10	8	8	8

FC																							
Modèles Models Modelle Modelos	P02			P04			P06			P08			P10			P12			P14		P16		
	A	B	D	A	B	D	A	B	D	A	B	D	A	B	D	A	B	D	A	B	A	B	
PI9M00002 - APK T 150/60	4	4	4																				
PI9M00003 - APK T 150/75				4	4	6	6	6	8			10			12			14	10	12			12
PI9M00004 - APK T 200/45										6	6		8	8		8	8		8	8			10

FI															
Modèles Models Modelle Modelos	L01			L02			L03			L04			L05		L06
	A	B	D	A	B	D	A	B	D	A	B	D	A	B	A
PI9M00001 - APK T 100/60	4	4	4												
PI9M00005 - APK T 100/75				4	4	4									
PI9M00002 - APK T 150/60							6	6	8			10	8	8	8
PI9M00003 - APK T 150/75										6	6				

FI																								
Modèles Models Modelle Modelos	P02			P04			P06			P08			P10			P12			P14		P16		P18	P20
	A	B	D	A	B	D	A	B	D	A	B	D	A	B	D	A	B	D	A	B	A	B	A	A
PI9M00003 - APK T 150/75	4	4	4	4	4	6																		
PI9M00004 - APK T 200/45							6	6	8	6	6	10	8	8	12	8	8	14	10	12	10	12	12	14

### 8.3 RE2 / RE3 / RE4 : Pieds rehaussés – Extended legs - Höhenverstellbare Füße - Patas realzadas - Поднятые ножки

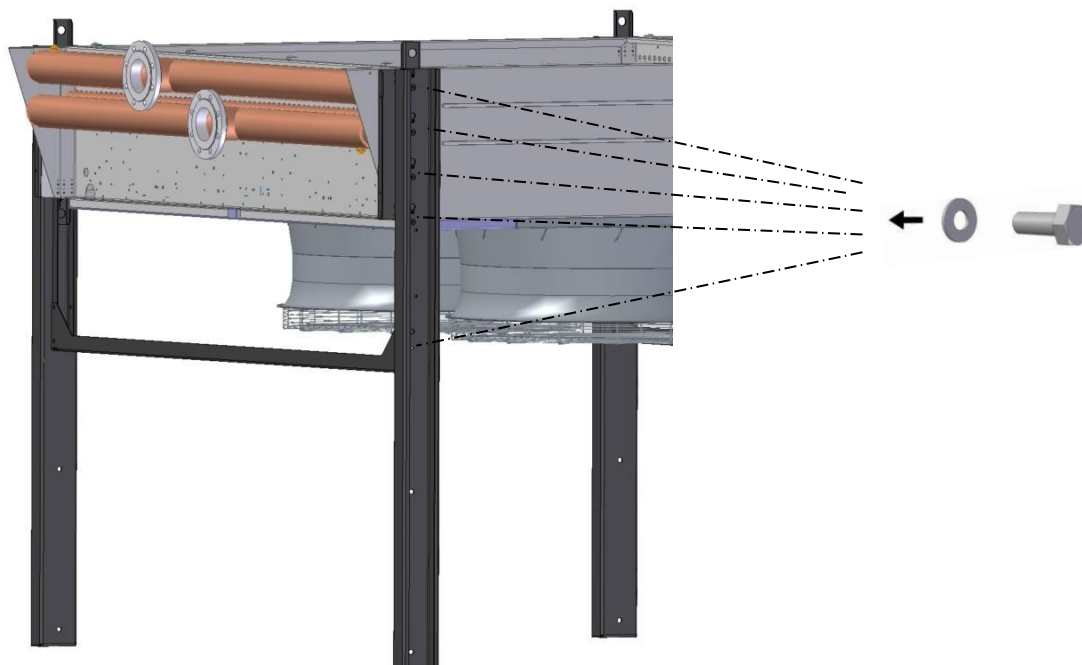

Modeles Models Modelle Modelos	Poids - Weight - Gewicht - Peso (kg)		
	REH2	REH3	REH4
... L01A	+ 60	+ 76	+ 102
... L01B	+ 60	+ 76	+ 102

... L01D	+ 60	+ 76	+ 102
... L02A	+ 60	+ 76	+ 102
... L02B	+ 60	+ 76	+ 102
... L02D	+ 90	+ 114	+ 152
... L03A	+ 90	+ 114	+ 152
... L03B	+ 90	+ 114	+ 152
... L03D	+ 120	+ 152	+ 203
... L04A	+ 90	+ 114	+ 152
... L04B	+ 90	+ 114	+ 152
... L04D	+ 150	+ 190	+ 253
... L05A	+ 120	+ 152	+ 203
... L05B	+ 120	+ 152	+ 203
... L06A	+ 120	+ 152	+ 203
... P02A	+ 60	+ 76	+ 102
... P02B	+ 60	+ 76	+ 102
... P02D	+ 60	+ 76	+ 102
... P04A	+ 60	+ 76	+ 102
... P04B	+ 60	+ 76	+ 102
... P04D	+ 90	+ 114	+ 152
... P06A	+ 90	+ 114	+ 152
... P06B	+ 90	+ 114	+ 152
... P06D	+ 120	+ 152	+ 203
... P08A	+ 90	+ 114	+ 152
... P08B	+ 90	+ 114	+ 152
... P08D	+ 150	+ 190	+ 253
... P10A	+ 120	+ 152	+ 203
... P10B	+ 120	+ 152	+ 203
... P10D	+ 180	+ 228	+ 304
... P12A	+ 120	+ 152	+ 203
... P12B	+ 150	+ 190	+ 253
... P12D	+ 210	+ 266	+ 354
... P14A	+ 150	+ 190	+ 253
... P14B	+ 180	+ 228	+ 304
... P16A	+ 150	+ 190	+ 253
... P16B	+ 180	+ 228	+ 304
... P18A	+ 180	+ 228	+ 304
... P20A	+ 180	+ 228	+ 304

#### 8.4 GDR : Grille de protection batterie – Coil guards -

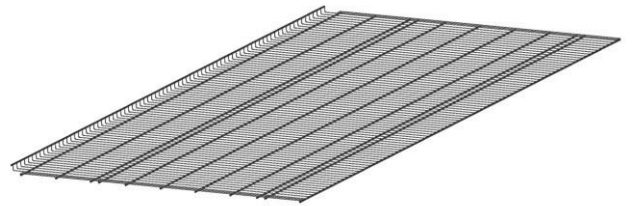

Modeles Models Modelle Modelos	Poids - Weight - Gewicht - Peso (kg)
	<b>GDR</b>
... L01A	+ 7
... L01B	+ 8
... L01D	+ 11
... L02A	+ 13
... L02B	+ 16
... L02D	+ 21
... L03A	+ 19
... L03B	+ 24
... L03D	+ 32
... L04A	+ 25
... L04B	+ 32
... L04D	+ 42
... L05A	+ 32
... L05B	+ 39
... L06A	+ 38
... P02A	+ 13
... P02B	+ 16
... P02D	+ 21
... P04A	+ 25
... P04B	+ 32
... P04D	+ 42
... P06A	+ 38
... P06B	+ 47
... P06D	+ 63
... P08A	+ 50
... P08B	+ 63
... P08D	+ 84
... P10A	+ 63
... P10B	+ 78
... P10D	+ 104
... P12A	+ 75
... P12B	+ 94
... P12D	+ 125
... P14A	+ 88
... P14B	+ 110
... P16A	+ 100
... P16B	+ 125
... P18A	+ 113
... P20A	+ 125



## 9. ENTRETIEN - MAINTENANCE - WARTUNG - MANTENIMIENTO - ОБСЛУЖИВАНИЕ

- **Doit être effectué par un personnel habilité et qualifié**

-Nettoyer périodiquement (≈3 mois) à l'aide d'un produit non agressif et rincer à l'eau claire :

-la batterie : pression maximale 3 bars et jet orienté face à la tranche des ailettes. Dans le cas de l'utilisation d'un système adiabatique l'entretien périodique est indispensable pour conserver les performances et l'intégrité de l'appareil -les hélices, les grilles et la carrosserie.



Vérifier à la mise en route et tous les 6 mois le serrage des vis d'assemblage, l'état et le serrage des composants électriques.

**DEFAUT DE FONCTIONNEMENT**

Le moteur ne tourne pas : avant toute intervention, vérifier l'alimentation électrique. S'assurer que l'hélice tourne librement.

L'appareil vibre : vérifier les hélices et remplacer le motoventilateur défectueux, s'assurer de l'absence de glace sur les hélices.

- **To be made by authorized and trained personnel**



-Clean periodically (≈3 months) with a non aggressive solution and rinse with clean water:  
 -coil: maximum 3 bars water pressure and jet facing the fin edges. When using an adiabatic system, periodic maintenance is essential to maintain the unit's performance and integrity. -fan blades, fan guards and casing. At start up and every 6 months, check for eventual loosen screws, the condition and tightening of the electrical connections.

**FAILURES**

Motor does not turn: before any intervention, check the electric supply. Make sure that the fan blade is turning freely.  
 The unit vibrates: check the fan blades and replace the fan assembly defective, make sure that fan blades are free of ice.



o **Durch qualifiziertes Personal durchgeführt werden**

-Folgende Teile regelmäßig (≈3 Monate) mit einem milden Reinigungsmittel reinigen und mit klarem Wasser spülen:  
 -Batterie: maximaler Druck des Wasserstrahls, der senkrecht zur Kante der Lamellen gerichtet sein muß: 3 Bar. Bei der Verwendung eines adiabatischen Systems ist die regelmäßige Wartung unerlässlich, um die Leistung und Integrität des Geräts zu erhalten

-Ventilatorflügel, Schutzgitter und Gehäuse.

Überprüfen Sie beim Start und alle 6 Monate, ob alle Schrauben gut festgezogen sind. Zustand und Befestigung der elektrischen Komponenten überprüfen.

**STÖRUNGEN**

Der Motor läuft nicht: vor jeglichem Eingriff Stromversorgung überprüfen. Prüfen, ob sich die Ventilatorflügel leichtgängig drehen.

Das Gerät vibriert: Ventilatorflügel überprüfen und defekten ventilatormotor austauschen. Sicherstellen, daß die Flügel nicht vereist sind.



o **Para ser realizado por personal autorizado y formado**

-Limpie periódicamente (≈3 meses) con un producto no agresivo y aclare con agua limpia:

-la batería: presión máxima 3 bares y chorro orientado paralelamente a las aletas. Cuando se utiliza un sistema adiabático, el mantenimiento regular es esencial para conservar el rendimiento y la integridad del aparato. -las hélices, las rejillas y la carrocería.

Verifique la puesta en marcha y cada 6 meses, el priete de los tornillos de ensambladura, el estado y la sujeción de los componentes eléctricos.

**FALLO DEFUNCIONAMIENTO**

El motor no gira: antes de cualquier intervención, verifique la alimentación eléctrica. Cerciórese de que el ventilador gira libremente.

El aparato vibra: comprobar las hélices y sustituir el motoventilador defectuoso, cerciorarse de que no haya hielo en las hélices.



o **Обслуживание должно выполняться квалифицированным специалистом**

-Периодически очищать (≈раз в 3 месяца) неагрессивным средством и промывать пресной водой:

-Теплообменник: максимальное давление 3 бара, струя должна быть направлена на край ребер. При использовании адиабатической системы для поддержания работоспособности и целостности прибора необходимо регулярное техническое обслуживание. -Крыльчатки, решетки и рама.

Проверить при вводе в эксплуатацию и затем раз в 6 месяцев затяжку крепежных винтов, состояние и затяжку электрических компонентов. **СБОИ В РАБОТЕ**

Двигатель не вращается: перед выполнением любых работ убедитесь в отключении электропитания.

Удостоверьтесь, что крыльчатка вращается свободно.

Вибрация устройства: проверьте крыльчатки и замените неисправные мотор-вентиляторы, убедитесь в отсутствии наледи на крыльчатках.

**10. PIÈCES DÉTACHÉES - SPARE PARTS - ERSATZTEILE - PIEZASSUELTAS - ЗАПАСНЫЕ ЧАСТИ**

Demandez notre catalogue "pièces détachées" - Ask for our liste of spare parts - Forden Sie unseren - Ersatzteilkatalog an - Pida nuestro catálogo "piezas de repuesto" - Отправьте нам запрос на каталог запасных частей

Tél. : +33 4 72 47 14 44

Fax : +33 4 72 47 13 99 42 rue Roger Salengro - BP 205 [parts.service@lennoxemea.com](mailto:parts.service@lennoxemea.com)

\_\_\_69741 GENAS CEDEX - FRANCE

**FRIGA-BOHN®**



**LFB France**

42 rue Roger Salengro - BP 205

69741 GENAS CEDEX - FRANCE

Tél. : +33 4 72 47 13 00 - Fax : +33 4 72 47 13 96

[www.frigabohn.com](http://www.frigabohn.com)

Friga-Bohn se réserve le droit d'apporter toute modification sans préavis.

Friga-Bohn reserves itself the right to make changes at any time without preliminary notice.

Friga-Bohn Angaben und Abbildungen unverbindlich. Änderungen vorbehalten.

Friga-Bohn se reserva el derecho de aportar cualquier modificación sin preaviso

Friga-Bohn zastrzega sobie prawo do wprowadzania zmian bez uprzedzenia

**FR NEOSTAR**

Dry coolers

N° IN0050500-C

01.2025